

How to Read a Datasheet

Prepared for the WIMS outreach program
5/6/02, D. Grover

In order to use a PIC microcontroller, a flip-flop, a photodetector, or practically any electronic device, you need to consult a datasheet. This is the document that the manufacturer provides telling you

- the typical device performance
- minimum and maximum requirements and characteristics
- what you can do to the device without harming it
- suggested uses and hints

Manufacturers want you, the designer, to have a successful experience with their device. They are trying to be helpful. They don't always succeed. The datasheet on the following pages is a relatively good datasheet. It tries to **concisely tell you everything you need** to know about the device, a common 555 timer chip (the duct-tape of the electronics hobbyist). Most datasheets ~~for ICs follow the same general layout.~~

You don't have to understand everything in a datasheet. There's a lot of information that might not be of any use to you. The annotations that follow try to point out parts of the datasheet that you should pay particular attention to.

Where do you find datasheets? Nowadays you can find almost any datasheet on the internet, often in PDF (Acrobat) form. For example, the LM555 datasheet from National Semiconductor is on their website at www.national.com.

What is the LM555? The LM555 is a timer chip that uses external resistors and capacitors to generate either a single pulse of a certain duration, or a continuous sequence of pulses with a variety of pulse widths possible. Because it is a very general purpose collection of functional blocks such as comparators, a flip-flop, internal voltage divider, high power output stage, and so on, a number of different timing-related functions are possible. Entire books have been written about the 555, though it is often used when another IC would work better. (See for example the CD4538 timer chip.)

There will always be a date. Datasheets do change, especially if Preliminary or Advance. Check the date!

February 2000

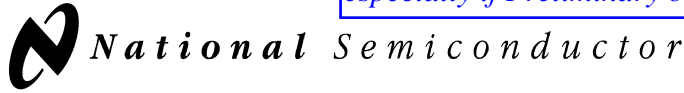

Look up here to see if the datasheet is Advance Information or Preliminary.

LM555 Timer

LM555 Timer

General Description

The LM555 is a highly stable device for generating accurate time delays or oscillation. Additional terminals are provided for triggering or resetting if desired. In the time delay mode of operation, the time is precisely controlled by one external resistor and capacitor. For astable operation as an oscillator, the free running frequency and duty cycle are accurately controlled with two external resistors and one capacitor. The circuit may be triggered and reset on falling waveforms, and the output circuit can source or sink up to 200mA or drive TTL circuits.

Sometimes the General Description will tell you about a feature or usage not mentioned anywhere else! For example, you might need to hold a specific pin low for some operation.

Features tell you general characteristics--always check the Electrical Characteristics for conditions and exceptions.

Features

- Direct replacement for SE555/NE555
- Timing from microseconds through hours
- Operates in both astable and monostable modes
- Adjustable duty cycle
- Output can source or sink 200 mA
- Output and supply TTL compatible
- Temperature stability better than 0.005% per °C
- Normally on and normally off output
- Available in 8-pin MSOP package

Applications

- Precision timing
- Pulse generation
- Sequential timing
- Time delay generation
- Pulse width modulation
- Pulse position modulation
- Linear ramp generator

Application suggestions can often tell you quickly if this device is in the ballpark for what you want to do, but these lists are often very general.

Schematic Diagram

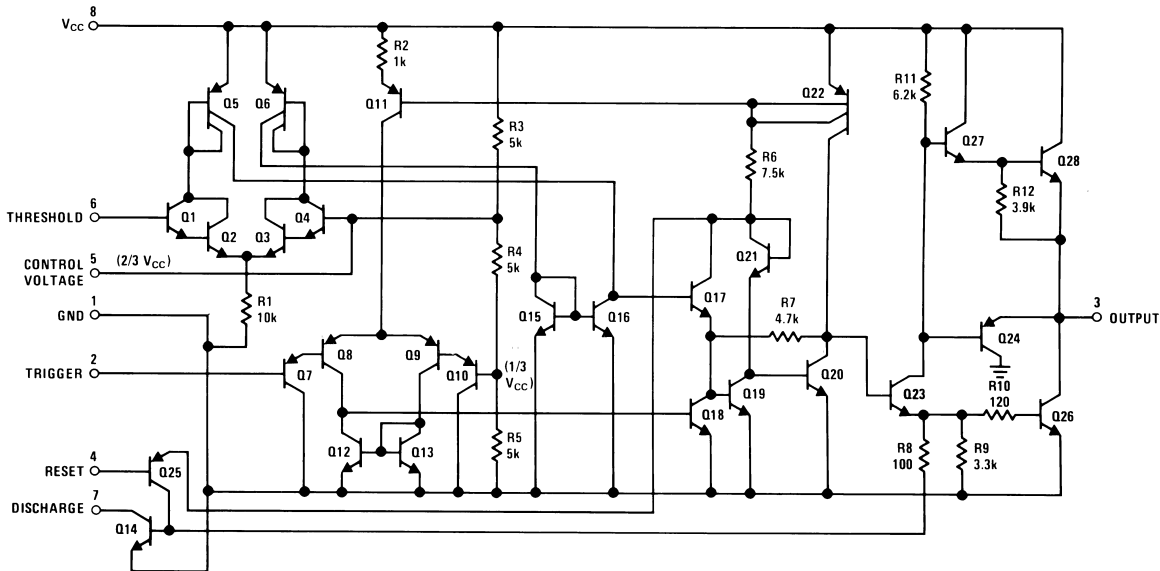

Usually called the Equivalent Schematic Diagram, this schematic isn't what is necessarily in the device, but the device acts as if this was what was inside. It can help explain behavior that isn't otherwise described in the datasheet. Could you duplicate this circuit on a breadboard? Only if you knew what the characteristics of the transistors were--which are not given.

Connection Diagram

Make sure you're looking at the pinout for the correct package. In the back pages you'll find drawings of the package types. Here all the packages have the same pinout--that's not always the case!

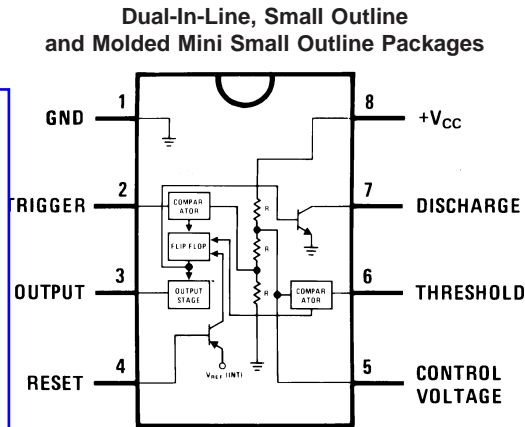

Ordering Information

Package	Part Number	Package Marking	Media Transport	NSC Drawing
8-Pin SOIC	LM555CM	LM555CM	Rails	M08A
	LM555CMX	LM555CM	2.5k Units Tape and Reel	
8-Pin MSOP	LM555CMM	Z55	1k Units Tape and Reel	MUA08A
	LM555CMMX	Z55	3.5k Units Tape and Reel	
8-Pin MDIP	LM555CN	LM555CN	Rails	N08E

Under Ordering Information you'll find a list of every variation of this device along with the COMPLETE part number. Often the first few letters are either industry-standard or identify the manufacturer (e.g., PIC). The generic identifier comes next ("555"). Suffixes generally give package type (surface mount and through hole types), temperature range (wider range = more expensive), speed (faster = more expensive), and other variations such as power, voltage range, etc.

Other elements in datasheets:

--Related devices, such as devices this supercedes, exactly replaces, or is replaced by

--Block diagrams of internals

--Information to support programming or configuring the device (registers, etc.)

--Interfacing with other devices (including input/output characteristics)

Absolute Maximum Ratings

See Note 2 for details.

If Military/Aerospace specified devices are required, please contact the National Semiconductor Sales Office/Distributors for availability and specifications.

Supply Voltage +18V

Power Dissipation (Note 3)

LM555CM, LM555CN 1180 mW

LM555CMM 613 mW

Operating Temperature Ranges

LM555C 0°C to +70°C

Storage Temperature Range -65°C to +150°C

Soldering Information
 Dual-In-Line Package
 Soldering (10 Seconds) 260°C
 Small Outline Packages (SOIC and MSOP)
 Vapor Phase (60 Seconds) 215°C
 Infrared (15 Seconds) 220°C
 See AN-450 "Surface Mounting Methods and Their Effect on Product Reliability" for other methods of soldering surface mount devices.

Electrical Characteristics are sometimes split into DC (power supply, static input/output characteristics) and AC or Timing, these tell you what you can count on.

Electrical Characteristics

(Notes 1, 2)

(T_A = 25°C, V_{CC} = +5V to +15V, unless otherwise specified)

Parameter	Conditions	Limits			Units
		Min	Typ	Max	
Supply Voltage		4.5		16	V
Supply Current	V _{CC} = 5V, R _L = ∞ V _{CC} = 15V, R _L = ∞ (Low State) (Note 4)		3 10	6 15	mA
Timing Error, Monostable	R _A = 1k to ∞ C = 0.1µF				%
Initial Accuracy					°C
Drift with Temperature					%
Accuracy over Temperature					%
Drift with Supply					%/V
Timing Error, Astable					%
Initial Accuracy					ppm/°C
Drift with Temperature					%
Accuracy over Temperature					%
Drift with Supply					%/V
Threshold Voltage					x V _{CC}
Trigger Voltage	V _{CC} = 15V		5		V
	V _{CC} = 5V		1.67		V
Trigger Current			0.5	0.9	µA
Reset Voltage		0.4	0.5	1	V
Reset Current			0.1	0.4	mA
Threshold Current	(Note 6)		0.1	0.25	µA
Control Voltage Level	V _{CC} = 15V	9	10	11	V
	V _{CC} = 5V	2.6	3.33	4	V
Pin 7 Leakage Output High			1	100	nA
Pin 7 Sat (Note 7)					
Output Low	V _{CC} = 15V, I ₇ = 15mA		180		mV
Output Low	V _{CC} = 4.5V, I ₇ = 4.5mA		80	200	mV

Watch out--the datasheet might discuss more than one part!

Design to the minimum and maximum limits, not to the typical. This gives you an idea of the likely behavior, but not the worst-case. Good, robust design does not count on the typical!

Pay attention to the conditions noted. Here the device is at a specific temperature. Often, plots later on in the datasheet will show temperature-related parameters (as well as those dependent on supply voltage, speed, etc.).

Electrical Characteristics (Notes 1, 2) (Continued)

($T_A = 25^\circ\text{C}$, $V_{CC} = +5\text{V}$ to $+15\text{V}$, unless otherwise specified)

Parameter	Conditions	Limits			Units
		LM555C			
		Min	Typ	Max	
Output Voltage Drop (Low)	$V_{CC} = 15\text{V}$				
	$I_{\text{SINK}} = 10\text{mA}$		0.1	0.25	V
	$I_{\text{SINK}} = 50\text{mA}$		0.4	0.75	V
	$I_{\text{SINK}} = 100\text{mA}$		2	2.5	V
	$I_{\text{SINK}} = 200\text{mA}$		2.5		V
	$V_{CC} = 5\text{V}$				
	$I_{\text{SINK}} = 8\text{mA}$				V
Output Voltage Drop (High)	$I_{\text{SOURCE}} = 200\text{mA}$, $V_{CC} = 15\text{V}$		12.5		V
	$I_{\text{SOURCE}} = 100\text{mA}$, $V_{CC} = 15\text{V}$	12.75	13.3		V
	$V_{CC} = 5\text{V}$	2.75	3.3		V
Rise Time of Output			100		ns
Fall Time of Output			100		ns

Note 1: All voltages are measured with respect to the ground pin, unless otherwise specified.

Note 2: Absolute Maximum Ratings indicate limits beyond which damage to the device may occur. Operating Ratings indicate conditions for which the device is functional, but do not guarantee specific performance limits. Electrical Characteristics state DC and AC electrical specifications under particular test conditions which guarantee specific performance limits. This assumes that the device is within the Operating Ratings. Specifications are not guaranteed for parameters where no limit is given, however, the typical value is a good indication of device performance.

Note 3: For operating at elevated temperatures the device must be derated above 25°C based on a $+150^\circ\text{C}$ maximum junction temperature and a thermal resistance of 106°C/W (DIP), 170°C/W (S0-8), and 204°C/W (MSOP) junction to ambient.

Note 4: Supply current when output high typically 1 mA less at $V_{CC} = 5\text{V}$.

Note 5: Tested at $V_{CC} = 5\text{V}$ and $V_{CC} = 15\text{V}$.

Note 6: This will determine the maximum value of $R_A + R_B$ for 15V operation. The maximum total ($R_A + R_B$) is $20\text{M}\Omega$.

Note 7: No protection against excessive pin 7 current is necessary providing the package dissipation rating will not be exceeded.

Note 8: Refer to RETS555X drawing of military LM555H and LM555J versions for specifications.

(Here is Note 2 in large print)

Note 2: Absolute Maximum Ratings indicate limits beyond which damage to the device may occur. Operating Ratings indicate conditions for which the device is functional, but do not guarantee specific performance limits. Electrical Characteristics state DC and AC electrical specifications under particular test conditions which guarantee specific performance limits. This assumes that the device is within the Operating Ratings. Specifications are not guaranteed for parameters where no limit is given, however, the typical value is a good indication of device performance.

Typical Performance Characteristics

Minimum Pulse Width Required for Triggering

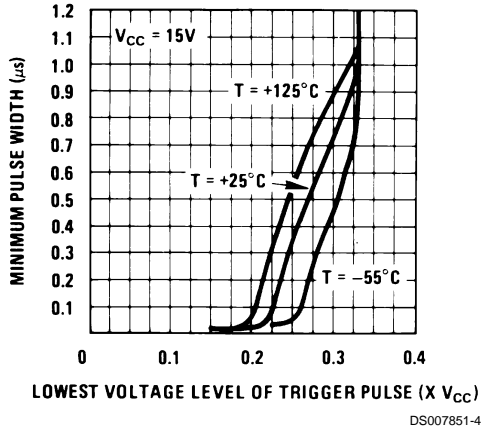

Supply Current vs. Supply Voltage

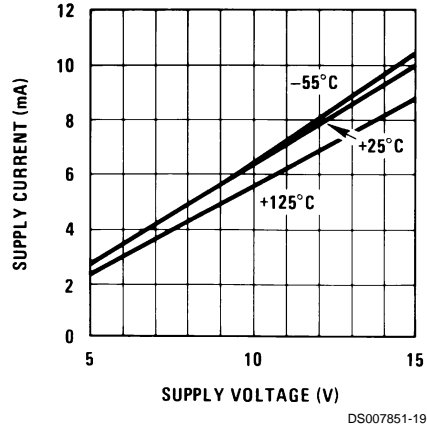

High Output Voltage vs. Output Source Current

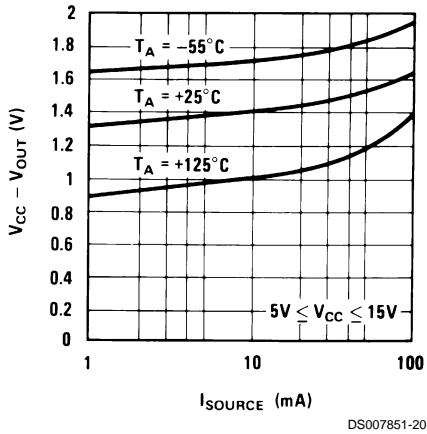

Low Output Voltage vs. Output Sink

Graphs are used to describe characteristics that can't be captured easily in a table. Often several things are being varied--above, supply current is measured as voltage is changed, but this is also being show for three different temperatures. Note that 25C is roughly room temperature (77F).

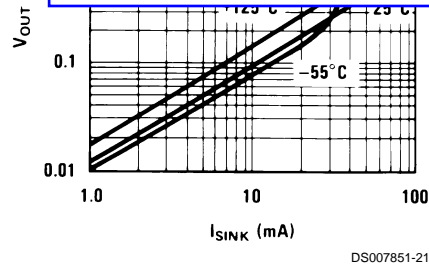

Low Output Voltage vs. Output Sink Current

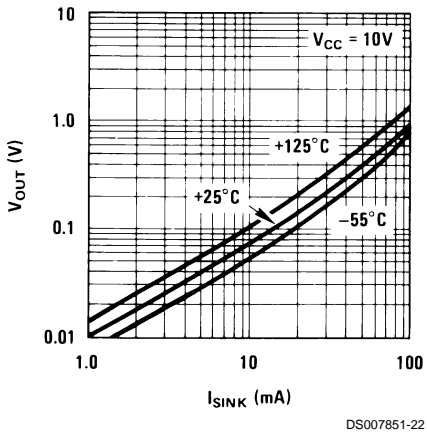

Low Output Voltage vs. Output Sink Current

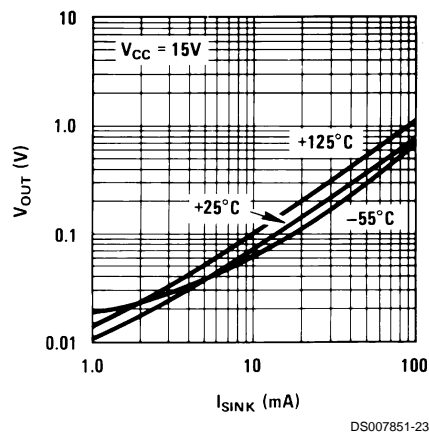

Page 6 of the datasheet is omitted.

Here are example circuits and application notes. Note too that often there are other sources for application information, such as separate Application Notes available from the manufacturer.

Applications Information

MONOSTABLE OPERATION

In this mode of operation, the timer functions as a one-shot (Figure 1). The external capacitor is initially held discharged by a transistor inside the timer. Upon application of a negative trigger pulse of less than $1/3 V_{CC}$ to pin 2, the flip-flop is set which both releases the short circuit across the capacitor and drives the output high.

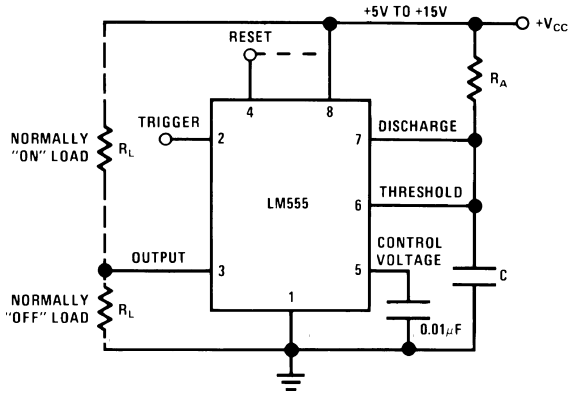

DS007851-5

FIGURE 1. Monostable

The voltage across the capacitor then increases exponentially for a period of $t = 1.1 R_A C$, at the end of which time the voltage equals $2/3 V_{CC}$. The comparator then resets the flip-flop which in turn discharges the capacitor and drives the output to its low state. Figure 2 shows the waveforms generated in this mode of operation. Since the charge and the threshold level of the comparator are both directly proportional to supply voltage, the timing interval is independent of supply.

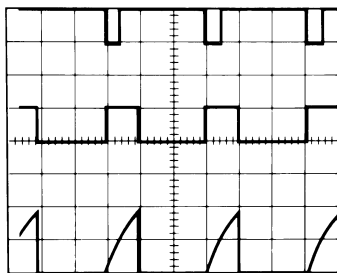

These waveforms would be helpful in debugging a circuit!

DS007851-6

$V_{CC} = 5V$ Top Trace: Input 5V/Div.
 TIME = 0.1 ms/DIV. Middle Trace: Output 5V/Div.
 $R_A = 9.1k\Omega$ Bottom Trace: Capacitor Voltage 2V/Div.
 $C = 0.01\mu F$

FIGURE 2. Monostable Waveforms

During the timing cycle when the output is high, the further application of a trigger pulse will not effect the circuit so long as the trigger input is returned high at least $10\mu s$ before the end of the timing interval. However the circuit can be reset during this time by the application of a negative pulse to the reset terminal (pin 4). The output will then remain in the low state until a trigger pulse is again applied.

When the reset function is not in use, it is recommended that it be connected to V_{CC} to avoid any possibility of false triggering.

Figure 3 is a nomograph for easy determination of R, C values for various time delays.

NOTE: In monostable operation, the trigger should be driven high before the end of timing cycle.

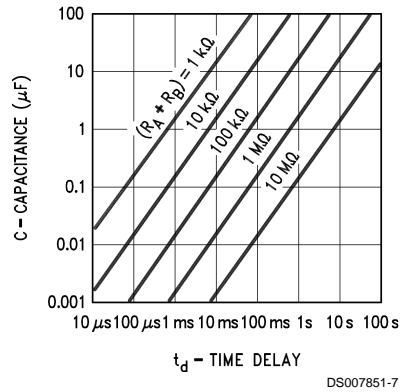

DS007851-7

FIGURE 3. Time Delay

ASTABLE OPERATION

If the circuit is connected as shown in Figure 4 (pins 2 and 6 connected) it will trigger itself and free run as a multivibrator. The external capacitor charges through R_A and discharges through R_B . Thus the duty cycle may be precisely set by the ratio of these two resistors.

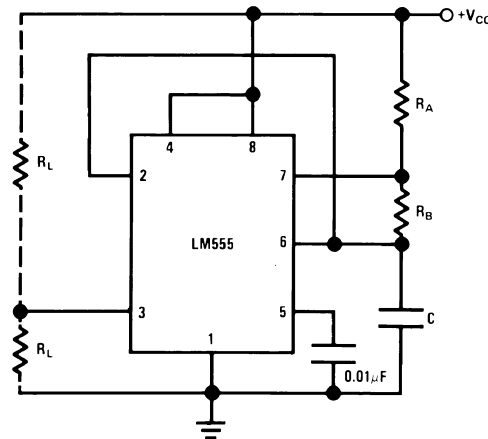

DS007851-8

FIGURE 4. Astable

In this mode of operation, the capacitor charges and discharges between $1/3 V_{CC}$ and $2/3 V_{CC}$. As in the triggered mode, the charge and discharge times, and therefore the frequency are independent of the supply voltage.

Not all datasheet application examples are so well written--sometimes you just get the raw schematics. For more complex devices, such as microcontrollers, different aspects might be handled in different sections--for example, a clock circuit in one part, a reset circuit in another. Read over all the sections to make sure you are using the device correctly and have supplied all the necessary components.

Pages 8-11 have been omitted.

Physical Dimensions inches (millimeters) unless otherwise noted (Continued)

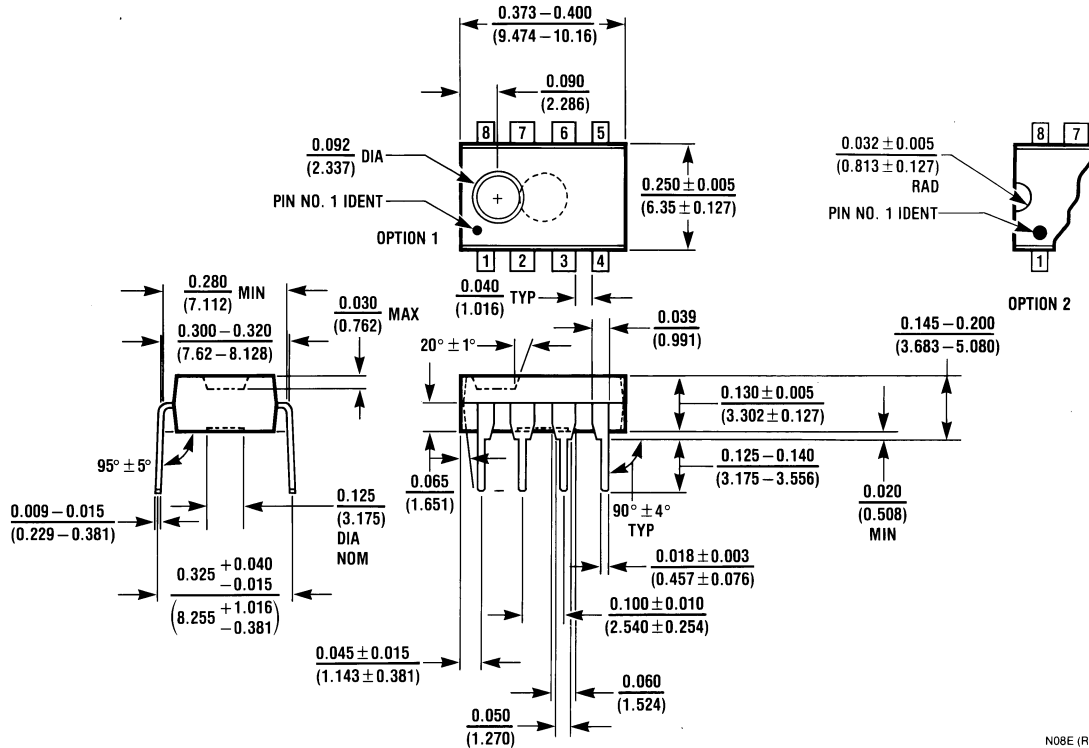

**Molded Dual-In-Line Package (N)
NS Package Number N08E**

N08E (REV F)

The package outlines can also be a source for pin-numbering if you are in doubt. Note that plastic DIP is the most common package for prototyping. Avoid surface mount packages (e.g., SOIC, MSOP, PQFP), though with the proper socket PLCC packages can be soldered to relatively easily (but not used in a plastic prototype board without an adapter). There is great variation in pricing depending on package type (and other factors such as temperature range, speed, etc.), so be sure to double-check part numbers.

LIFE SUPPORT POLICY

NATIONAL'S PRODUCT DEVELOPMENT DEVICES OR COUNSEL OF

Finally, remember that datasheets can always be in error. But just like programming, 99% of errors are user errors. If you find what you think is an error, make sure you have the most recent datasheet, and send a polite query to the appropriate technical support. Newsgroups such as sci.electronics.design might be useful to query first.

LIFE SUPPORT AND GENERAL

1. Life support systems whose failure to perform when properly used in accordance with instructions for use provided in the labeling, can be reasonably expected to result in a significant injury to the user.

component of a life support system, or to affect its safety or effectiveness.

failure to perform or to affect its safety or effectiveness.

National Semiconductor Corporation
Americas
Tel: 1-800-272-9959
Fax: 1-800-737-7018
Email: support@nsc.com
www.national.com

National Semiconductor Europe
Fax: +49 (0) 180-530 85 86
Email: europe.support@nsc.com
Deutsch Tel: +49 (0) 69 9508 6208
English Tel: +44 (0) 870 24 0 2171
Français Tel: +33 (0) 1 41 91 8790

National Semiconductor Asia Pacific Customer Response Group
Tel: 65-2544466
Fax: 65-2504466
Email: ap.support@nsc.com

National Semiconductor Japan Ltd.
Tel: 81-3-5639-7560
Fax: 81-3-5639-7507